

# INTELART

# IM240 V1.0

Analog input/output Module

User Manual

[www.intelart.ir](http://www.intelart.ir)

08/2021

## Warning notice system

This manual contains notices you have to observe in order to ensure your personal safety, as well as to prevent damage to property. The notices referring to your personal safety are highlighted in the manual by a safety alert symbol, notices referring only to property damage have no safety alert symbol. These notices shown below are graded according to the degree of danger.

### **DANGER**

indicates that death or severe personal injury will result if proper precautions are not taken.

### **WARNING**

indicates that death or severe personal injury may result if proper precautions are not taken.

### **NOTICE**

indicates that property damage can result if proper precautions are not taken.

## Qualified personnel

The product/system described in this documentation may be operated only by personnel qualified for the specific task in accordance with the relevant documentation, in particular its warning notices and safety instructions.

Qualified personnel are those who, based on their training and experience, are capable of identifying risks and avoiding potential hazards when working with these products/systems

Contents

Warning notice system ..... I

Qualified personnel..... I

1 Technical Specifications ..... 1

    1.1 Hardware Parameters ..... 1

2 Configurations..... 2

    2.1 Digital Outputs ..... **Error! Bookmark not defined.**

        2.1.1 Stop action ..... 2

3 Address Space ..... 3

4 Diagnostic and Wiring..... 4

5 Dimensional drawing ..... 6

# 1 Technical Specifications

## 1.1 Hardware Parameters

The module has four analog slots. Each analog slot hosts an analog module. All analog modules have one or two analog channels depending on their operation type.

The following table specifies the hardware information of the module.

*Table 1 Hardware parameters*

<b>Analog Slots</b>	Slots count	4
	Channels count	8
	Stop action support	Based on installed module
<b>Dimensions</b>	Width	30mm
	Height	102mm
	Depth	58mm
<b>Ambient Conditions</b>	Storage temperature	-15 to 75 °C
	Operating temperature	0 to 55 °C
<b>Miscellaneous</b>	Weight	Approx. 90g
	Power LED	Yes. Green LED
	Diagnostic LED	Yes. Yellow LED

## 2 Configurations

### 2.1 Analog Slots

Some properties will be accessible or unreachable based on the selected module type.

#### 2.1.1 Stop action

Each output channel has a property named “StopAction” which determines the act of channel when PLC state changes to stop mode.

#### 2.1.2 Smoothing

When you install an input analog module, a property named “Smoothing” will be appeared in properties window in order to enable some filtering and signal conditioning options.

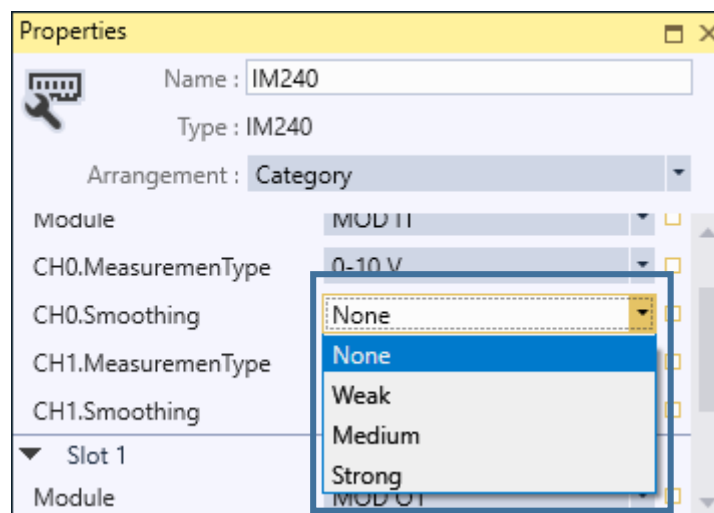

Figure 1 Analog input smoothing modes

# 3 Address Space

The value of input channels and output channels and some configurations will be accessible via an address space. There are bunch of predefined mapped tags in order to read or write a value in the address space. The following table illustrates the type and purpose of each mapped tag.







*Table 2 Mapped tags of parameters in the address space*

Category	Name	Data Type	Address	Function
<b>Input Space (I)</b>				
<b>Analog Inputs</b>	AI00	REAL	%ID0	Gets the value of channel 0 value
	AI01	REAL	%ID4	Gets the value of channel 1 value
	AI02	REAL	%ID32	Gets the value of channel 2 value
	AI03	REAL	%ID36	Gets the value of channel 3 value
	AI04	REAL	%ID64	Gets the value of channel 4 value
	AI05	REAL	%ID68	Gets the value of channel 5 value
	AI06	REAL	%ID96	Gets the value of channel 6 value
	AI07	REAL	%ID100	Gets the value of channel 7 value
<b>Diagnose</b>	DiagInfo	WORD	%IW104	Gets all diagnostic information when the module is in RUN mode. <ul style="list-style-type: none"> <li>• Bit0- Bit15: Reserved</li> </ul>
<b>Output Space (Q)</b>				
<b>Digital Outputs</b>	AQ00	REAL	%QD0	Sets the value of channel 0 value
	AQ01	REAL	%QD4	Sets the value of channel 1 value
	AQ02	REAL	%QD32	Sets the value of channel 2 value
	AQ03	REAL	%QD36	Sets the value of channel 3 value
	AQ04	REAL	%QD64	Sets the value of channel 4 value
	AQ05	REAL	%QD68	Sets the value of channel 5 value
	AQ06	REAL	%QD96	Sets the value of channel 6 value
	AQ07	REAL	%QD100	Sets the value of channel 7 value

## 4 Diagnostic and Wiring

The module has 2 LEDs indicating the status of module. The following table explains the combination of these two LEDs state.

Table 3 Combination of "POWER" and "MAINT" LEDs

LED		Indicating	Solution
POWER	MAINT		
 Off	 Off	Power missing or hardware failure.	<ul style="list-style-type: none"> <li>• Check the main power supply</li> <li>• Verify that the module is installed correctly</li> </ul>
 On	 On	The module is configured and is in RUN mode.	--
 On	 Flashes	Indicates an error (communication error, configuration error etc.)	<ul style="list-style-type: none"> <li>• Verify that the module is installed correctly</li> </ul>

The following block diagram shows you information about wiring of the module.

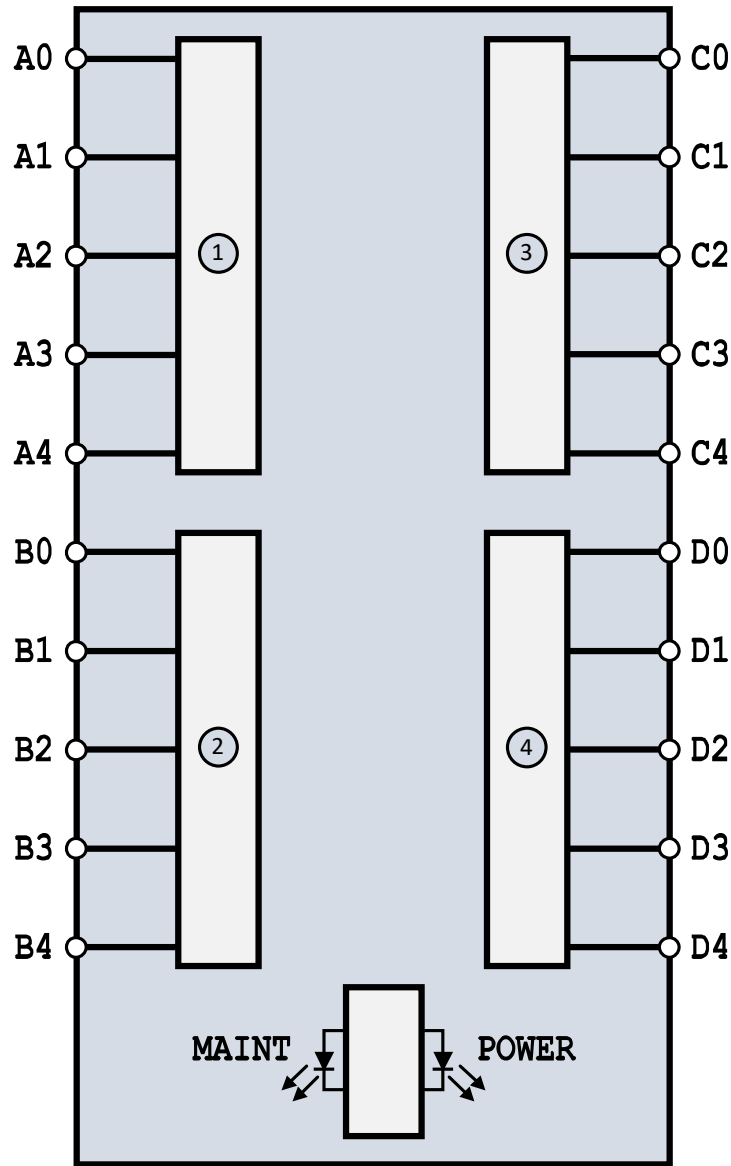

Figure 2 Wiring diagram and terminal assignments

- |               |               |               |                        |
|---------------|---------------|---------------|------------------------|
| ①             | Analog slot 0 | <b>Ax:</b>    | Analog slot 0 Terminal |
| ②             | Analog slot 1 | <b>Bx:</b>    | Analog slot 1 Terminal |
| ③             | Analog slot 2 | <b>Cx:</b>    | Analog slot 2 Terminal |
| ④             | Analog slot 3 | <b>Dx:</b>    | Analog slot 3 Terminal |
| <b>POWER:</b> | Power LED     | <b>MAINT:</b> | Maintenance LED        |



# 5 Dimensional drawing

The dimensions of the module are available in this section. For install the module and its main device follow the below dimensional drawing.

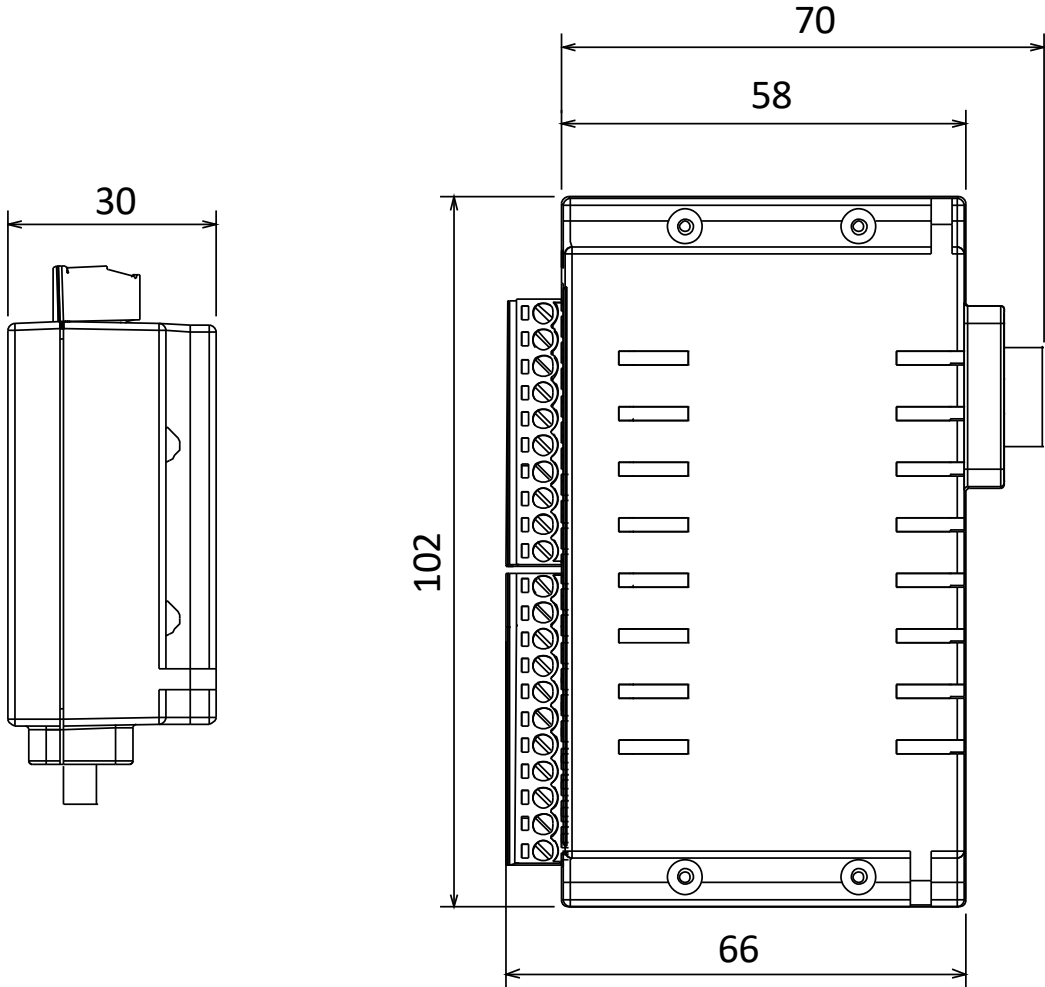

Figure 3 Dimensional drawing of IM240 module