

VOLUMETRIC FLOW METER

Precise digital flow-meter with on-unit display and control keys

OVERVIEW

FM units are sensors measuring the flow of gases. These devices are used in a wide range of laboratory and industrial applications in various fields of science such as pharmaceuticals, petroleum, chemicals and petrochemicals, medical, and semiconductor industry.

IRASOL devices employ state-of-the-art technologies to determine the rate of gas flow based on the differential pressure as a result of gas fluid.

IRASOL Products are produced in a number of models and accurately cover a range of 0 to 1000 standard cm³/min, depending on their application.

FEATURES

- Monitor and control keys on the device
- Device control by computer
- Device controlling software
- No need to a separate control unit
- High accuracy of measurement
- Measurement for different gases

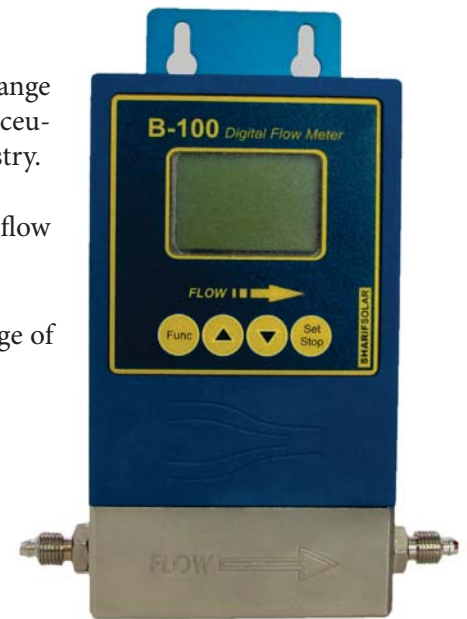

SPECIFICATIONS

FM Technical Specifications		
Max Inlet Pressure	7 Bar	
Min Outlet Pressure*	0.2 Bar	
Differential Pressure Range	<40 mBar	
Resolution	0.1% Full scale	
Repeatability	±0.2% Read point	
Accuracy	±1% Full scale	
Operating temperature	0 -45 °C	
Measuring range	Model	
	FM-50B	0-50 sccm
	FM-100B	0-100 sccm
	FM-200B	0-200 sccm
	FM-500B	0-500 sccm
FM-1000B	0-1000 sccm	
Case Material	Aluminum	
LCD Display	Simultaneously displays pressure, maximum flow and current flow	
Digital Outlet Signal	USB command base	
Warning Alarm	> Max. flow	
Power	12 VDC, 2 A	
Electrical Connection	DC Jack	
Dimension (L×H×W)	11.8 cm × 13.5 cm× 3.0 cm	
Weight	0.8 Kg (1.0 Kg for FM-1000B)	

HOW IT WORKS

In IRASOL FM units, a Laminar flow sensor is used to measure the gas flow. As it is observed in Figure 1, the laminar flow sensor consists of a thin pipe, across which a pressure difference is developed by the flow of gas.

The volumetric flow rate of the gas depends approximately on the difference in pressure between the two sides. It is possible to measure the mass flow by measuring the pressure difference, absolute pressure, and gas characteristics.

The advantage of this method is that measuring a pressure difference with very high accuracy is possible and moreover, the relationship between the pressure difference and the gas flow is almost linear.

Although the physical concept of the sensor is simple, there are various considerations to make the measurement precise and reliable. For instance, errors due to non-laminar gas flow, in particular at the inner and outer orifices lead to non-linear effects, which should be taken into account. The effect of temperature is also important in the sensing process and should be excluded.

Function diagram of the device is illustrated in Figure 2. The control circuit is connected to the LCD and control keys and reads the pressure and temperature values of the sensors and orders to the solenoid valve. The calculated or regulated flow is displayed on the monitor and in addition, the control circuit can be used to display and transfer of the data from/to a computer.

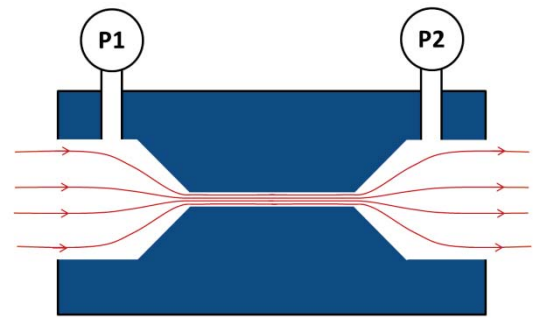

Figure 1. Schematic illustration of the method of gas flow measurement by means of a laminar sensor.

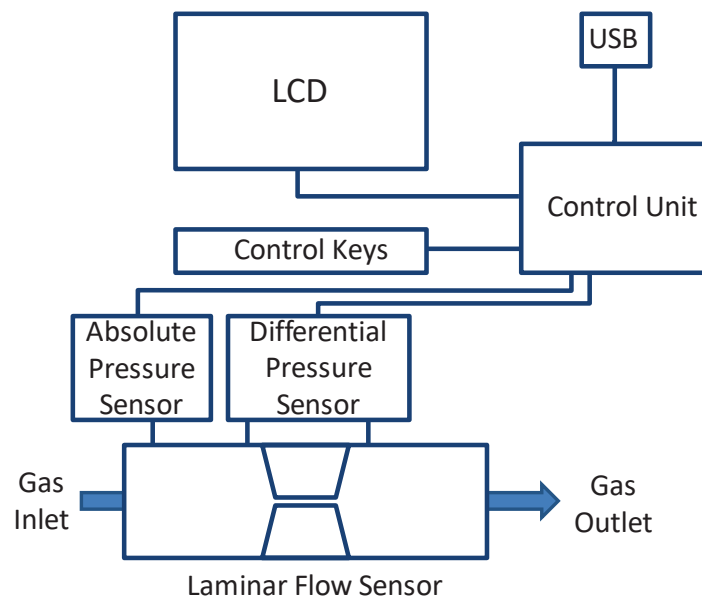

Figure 2. Function diagram of the FM