

RAXON160HPO is a high-power industrial X-ray source for producing a beam of high intensity X-rays with small focal spot and high stability which ensures uniform beam intensities and dose rate throughout its fan/cone-shaped beam. Stable voltage and electrical power applied to the X-ray tube guarantees stable dose exposure and high-quality images in digital radiography applications.

Applications

Industrial Radiography
X-ray Imaging
X-ray Irradiation
Non-Destructive Testing
Food Inspection
Security Inspection
Densitometry and Thickness Measurement

Specifications

X-ray Characteristics

Tube Type

Stationary anode, Glass tube, Tungsten target, Be filter

Focal Spot

0.8mm (IEC 336)

Beam Filter

3mm thick 6061 Al, ± 0.01

Beam Geometry

Symmetrical fan up to $75^\circ \times 30^\circ$, cone up to 40° (Optional)

Input Voltage

220 ± 10 Vac, 50/60Hz, 5A maximum

X-ray Tube Voltage

Nominal X-ray tube voltage is adjustable between 80kV to 160kV with 10kV step.

X-ray Tube Current

0.2mA to 4mA over specified tube voltage range

X-ray Tube Power

600W, continuous mode (can be increased on customer's demand)

Voltage Regulation

Line: $\pm 0.1\%$ for a $\pm 10\%$ input line change of nominal input line voltage

Load: $\pm 0.1\%$ for a 0.2mA to 4mA load change

Voltage Accuracy

Voltage measured across the X-ray tube is within $\pm 2\%$ of the programmed value

Voltage Risetime

Ramp time shall be < 200 ms from 10% to 90% of rated output

Voltage Overshoot

Within 5% of rated voltage in < 10 ms

Voltage Ripple

1% pp of rated voltage @ ≤ 1 kHz

Current Regulation

Line: $\pm 0.1\%$ for a $\pm 10\%$ input line change of nominal input line voltage

Load: 0.5% @ 80-160kV, 0.2mA to 4mA

Current Accuracy

Current measured through the X-ray tube is within $\pm 2\%$ of the programmed value

Current Risetime

< 200 ms from 10% to 90% of rated output



Arc Intervention

4 arcs in 10 seconds with a 200ms quench = Shutdown

Filament Configuration

Internal high frequency AC filament drive with closed loop filament emission control

Digital Interface

RS-232/USB/Ethernet Interface selectable port

Control Software

A demo GUI for engineering evaluations will be provided for the RS-232/USB/Ethernet digital interface and Encoded Command Port for customized software

Emergency Stop

A physical emergency stop is embedded for prompt shut down in case of emergency independent of software and microcontroller modules

Operating Temperature

0°C to +40°C

Storage Temperature

-40°C to +70°C

Humidity

10% to 95% relative humidity, non-condensing

Tube Cooling

Oil circulation and cooling

Motherboard Cooling

Natural convection augmented by customer provided 250cfm cooling fans for continuous operation

Input Power Line Connector

Standard 3pin Line-Null-Earth connector

Dimensions

645mm X 325mm X 300mm

Weight (Approx.)

40 kg

Installation Orientation

Can be mounted in any orientation.

Beam Orientation

Beam divergence angle: 75 degrees symmetrical

X-ray Leakage

Not to be greater than 1mR/hr at 50cm outside the external surface

Ultra-Low Leakage Dose Option

ULLD option is available on request. For this option, radiation leakage will be less than 0.5mR/hr at 5cm outside the external surface

Accessories

RS-232/USB connection cable

Ethernet connection cable

User Manual

Software

Fan Beam External Collimator (Cone Beam optional)

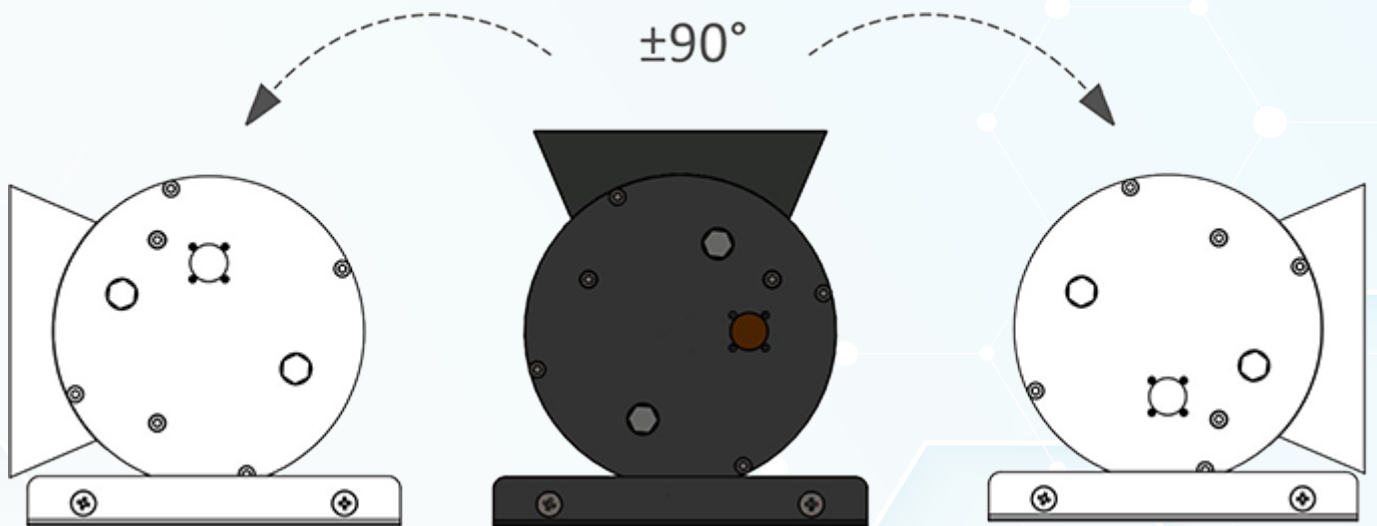
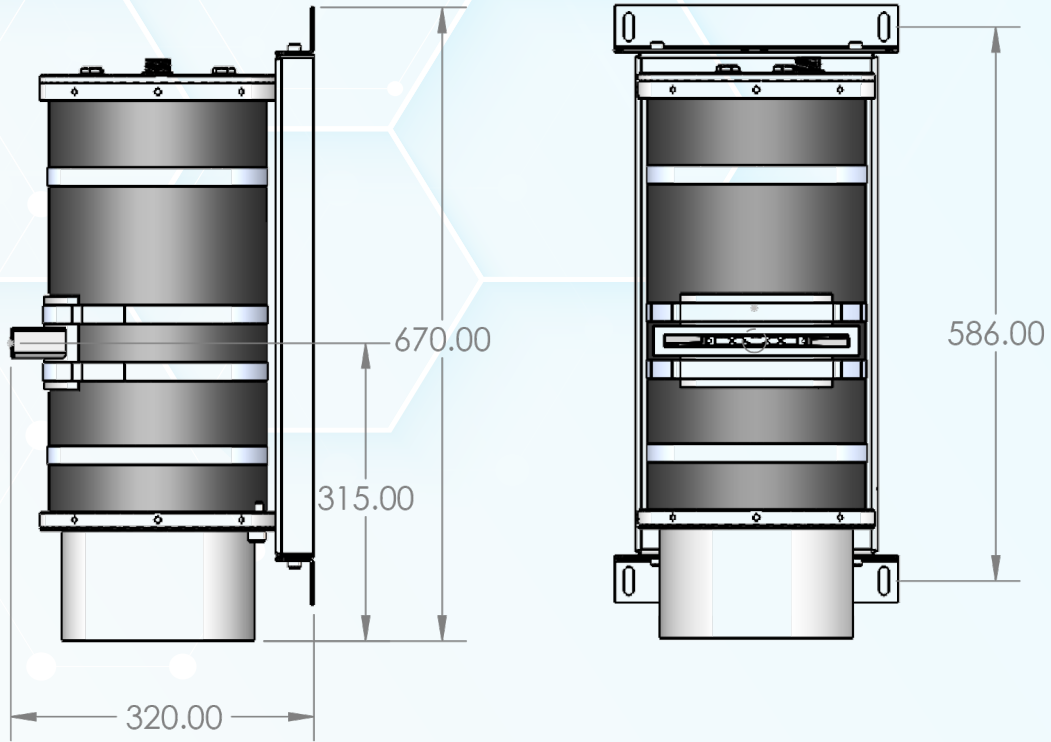

Dimensions are in millimeters