

# Hamgar Toos Co.

---

A MEMBER OF PARTLASTIC GROUP

# Content

---

## Chapter 1 – Who We Are?

- Company Profile
- History
- Missions & Visions
- Business Scope
- Key Numbers

# Company Profile



## About Us

---

Hamgar Toos (HT) company was established in 1993 as the main supplier of machine, mold and tool for Partlastic group. In machinery field, we provide cutting solutions in rubber and plastic industries, whether in downstream extrusion lines or finishing stations. Furthermore, our technical knowledge and long experience specialized us in design and manufacturing of special-purpose machinery used in different kinds of industries including automotive, medical and etc.



# History



Hamgar Toos company was established as the second member of Partlastic group

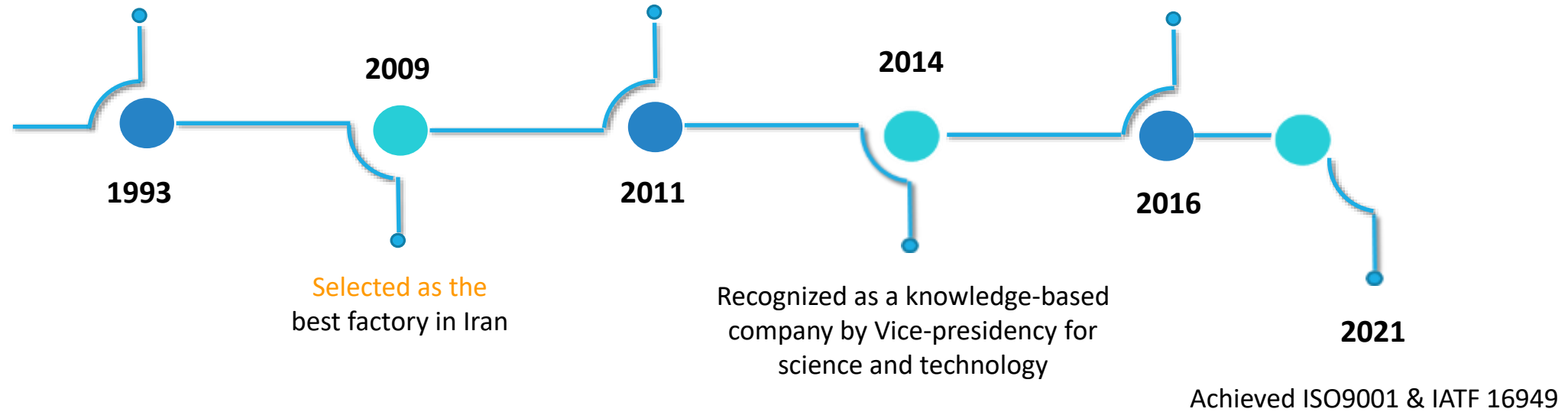

# Missions & Visions

---

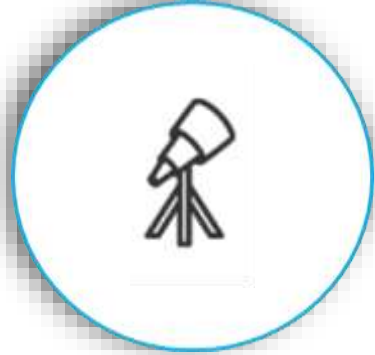

## **Perspective**

Introducing Hamgar Toos as a world class engineering company in design and manufacturing machines and molds

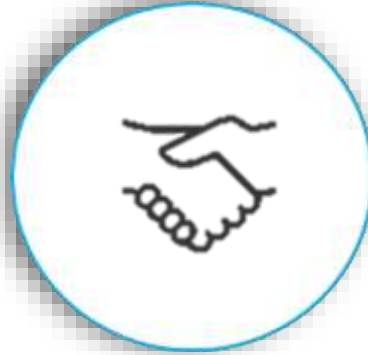

## **Commitment**

Attaining customer satisfaction with presenting excellent quality, value and state-of-the-art technology

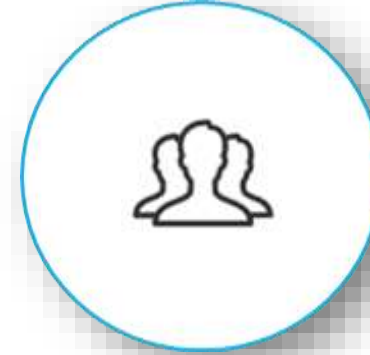

## **Workforce**

Promote knowledge, skills and abilities of employees

# Business Scope

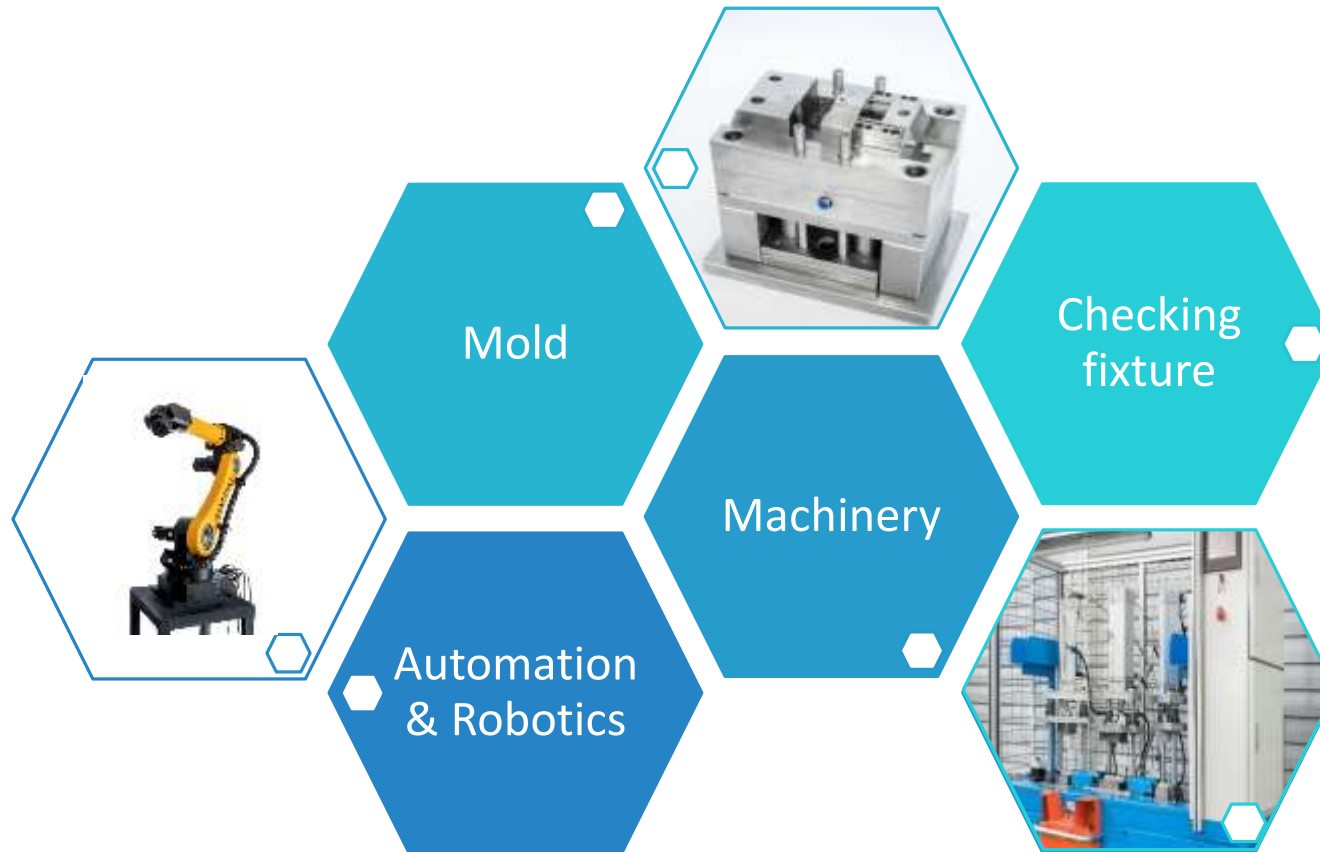
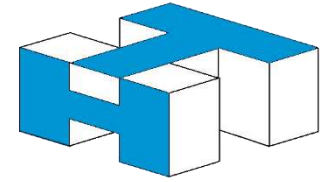

# Key Numbers

---



**40** Engineering Personnel, **54%** MSc



**1,000** Machines, **6,000** Dies  
**4,000** Molds, **67,000** Machinery parts

# Content

---

## Chapter 2 – What We Have?

- Equipment
- Processes
- FUM & HT Collaboration
- Our Footprints
- Our Customers



# Equipment

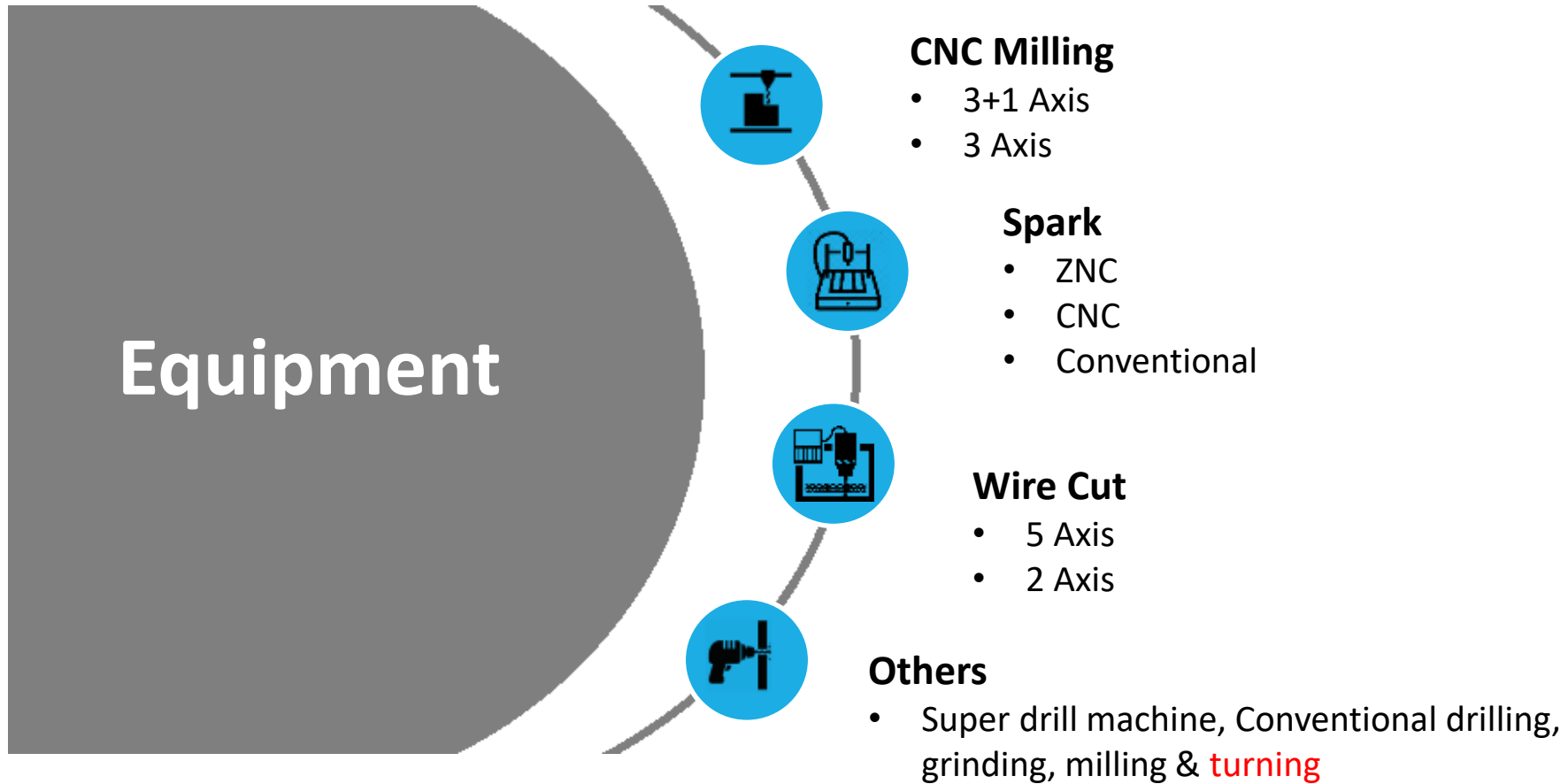

# Processes

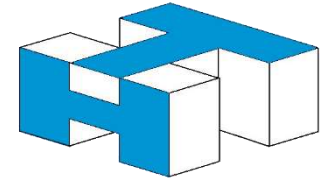

## Value-Added Services

➤ Computer-Aided Design & Analysis

Machine	Automation	Vision
<ul style="list-style-type: none"><li>• SOLIDWORKS</li><li>• Abaqus</li></ul>	<ul style="list-style-type: none"><li>• TIA Portal</li><li>• CX-One</li></ul>	<ul style="list-style-type: none"><li>• HALCON</li><li>• Qt Creator</li></ul>



# Processes

---

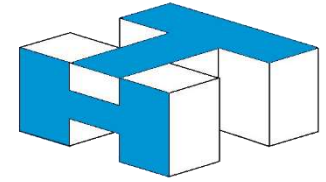

## ➤ Reverse Engineering (RE)

- Design and manufacturing one-off piece of equipment based on expected technical outputs or product features
- Integrate new technologies and features into existing systems

## ➤ Research & Development Activities

- Research and analyse new trends within the industry

# Processes

---

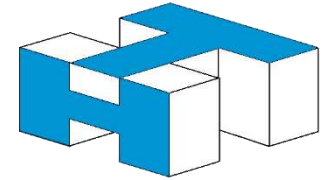

## Machining & Assembly

- Traditional and non-traditional machining operations
- Part quality check in every step of machining processes
- Mechanical, hydraulic, pneumatic and electrical assembly procedures



# FUM & HT Collaboration

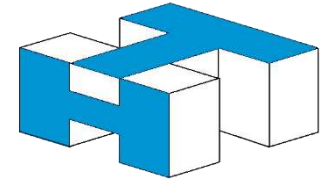

Since 2015, mutual technical and scientific cooperation between FUM Robotics Lab and HT

This collaboration has led to introducing the first national 6Axia robot

Beside technical support, HT funds FUM robotics projects

# FUM & HT Collaboration

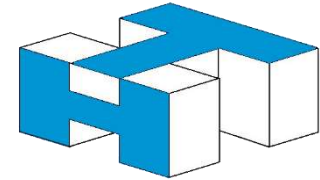

## Dr. Alireza Akbarzadeh Tootoonchi



Professor of Mechanical Engineering in Ferdowsi University of Mashhad (FUM) and supervisor of FUM robotics lab

47

MSc and PhD theses supervision

163

Publications in national and international conferences and journals

## FUM Robotics Lab

- FUM Knee physio
- FUM Zippy Wrist-Star Spherical
- FUM Industrial SCARA Robot

# Our Footprints

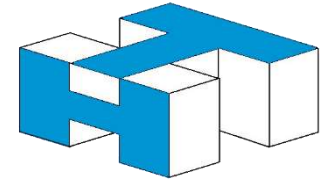

# Our Customers

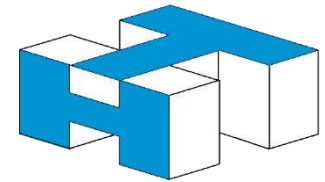

Customer Reference:





# Content

---

## Chapter 3 – What We Do?

- Machinery
- Automation Solutions
- Molds & Tools
- **Checking fixture**

# What We Do?

---

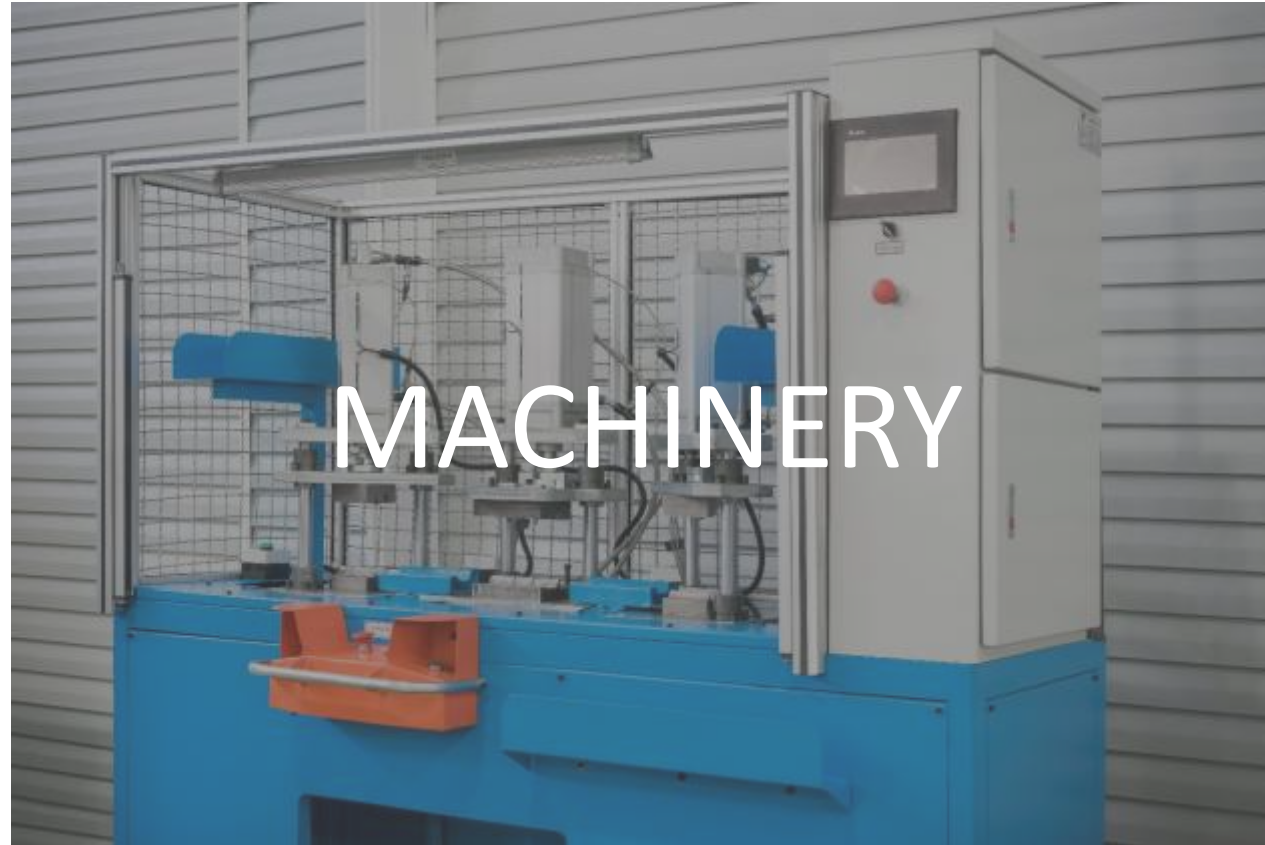
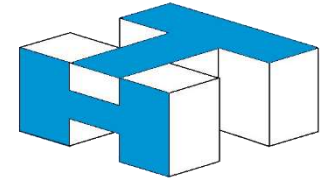

# Cutting Machines

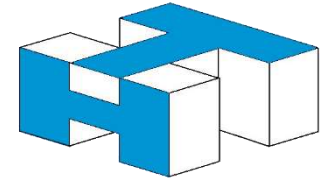

## Finishing Cutting Machines

We provide cutting solutions for complex processing of metal-reinforced, rigid or flexible profiles, hoses and tubes in rubber and plastic industries. The outputs are High quality processed and ready for assembly parts. Other possibilities to consider are end-processing procedures including notching finishing with end cutting and drilling finishing to provide location holes for sealing systems. Cutting machines possess the following features and possibilities:

- Cut-to-length and exact repeatability
- Single, multiple or interchangeable tools
- Sensors to monitor part flatness and position
- Checking fixtures to verify finished parts

# Finishing Cutting Machine

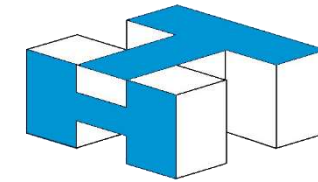

Master & Slave Cutting Machine

Profile halving and end processing in separate stations



Multiple Stations Cutting Machine

Profile halving and end punching simultaneously



Automatic Single-Pass Cutting Machine

Profiles are taken into the machine automatically and processed profiles are delivered

# Cutting Machines

---

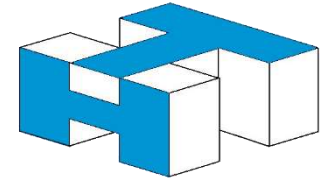

## Extrusion Cutting Machines

We provide machinery employed in downstream extrusion lines in rubber and plastic industries. Our cutting solutions include circular cutting machines, fly knife cutting machines and etc. In automotive industry, they are employed to process automotive components such as seals, weather-strips, hoses and tubes.

# Extrusion Cutting Machine

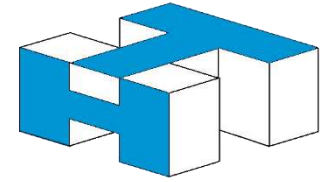

## Flying Cutting Machine

- Processes rigid rubber profiles and car door moldings
- Cutting speed is synchronized with production line speed

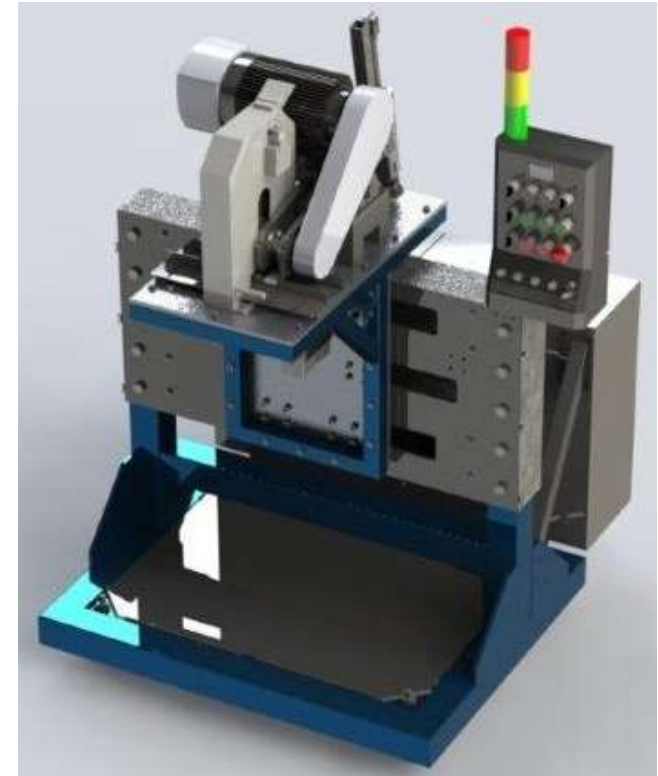

# Special-Purpose Machinery

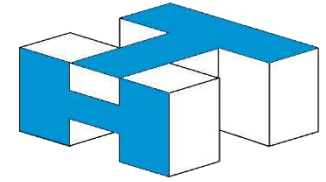

Our wide range of expertise and experience, enable us to design and manufacture Special-Purpose Machinery (SPM) tailored to our customer exact needs. We can deliver customer expected functions and performance requirements or supposed product features like dimensions and tolerances in automated tasks and mechanisms. In other words, SPMs are engineered to perform specific and customized operations. In the following some samples of our manufactured SPMs are listed:

- Coating Machines
- Forming Machines
- Assembly Machines
- Stretch Bending Machine
- Batch-off Machine

# Special-Purpose Machinery

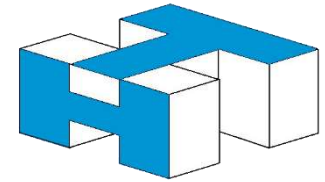

## Metal Adhesive Coater Machine

- Spraying coating method
- Coats metal parts with complex forms
- Index table with 24 stations
- Two stages of coating and curing





# Special-Purpose Machinery

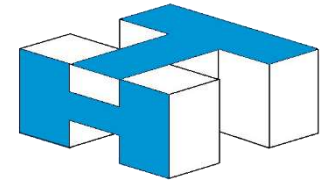

## Roller Gluing Machine

- Roll coating method
- Coats bush shaped metal parts
- Employs feeder to sort parts and feed them into the machine



# Special-Purpose Machinery

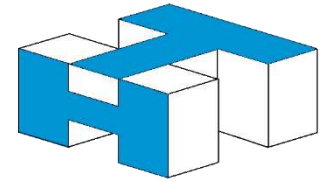

## Robotic Coating Machine

- Coats rubber parts
- Robot used to spray primer and coat material
- The profiles are cured in an IR oven



# Special-Purpose Machinery

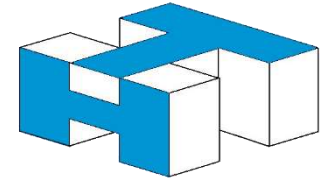

## Thermoforming Machine

- Forms multi-layer fuel hoses
- Employs a series of procedures to stabilize the desired form

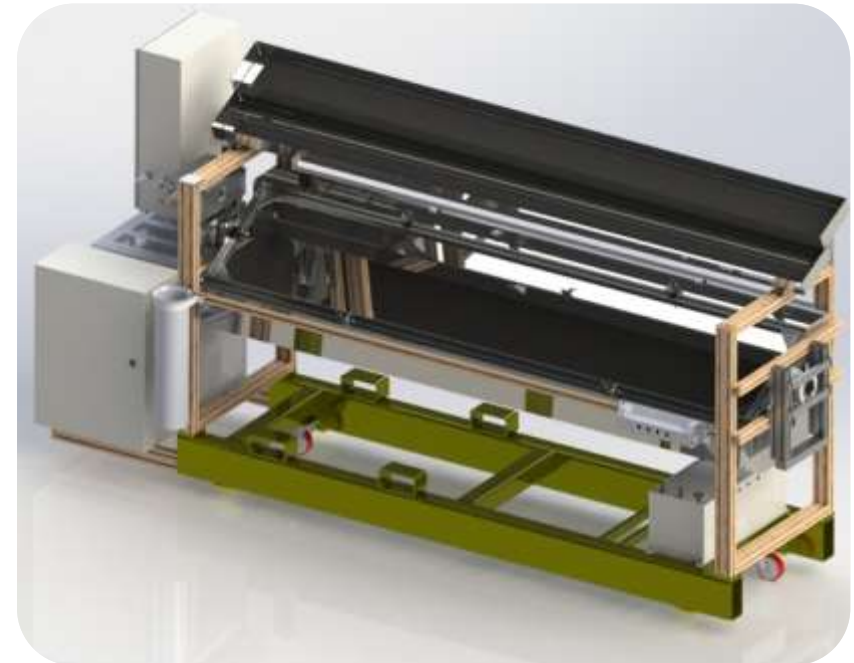

# Special-Purpose Machinery

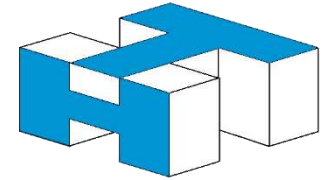

## Stretch Bending Machine

- Processes rigid profiles and car door moldings
- Stretching and bending operations with end cutting

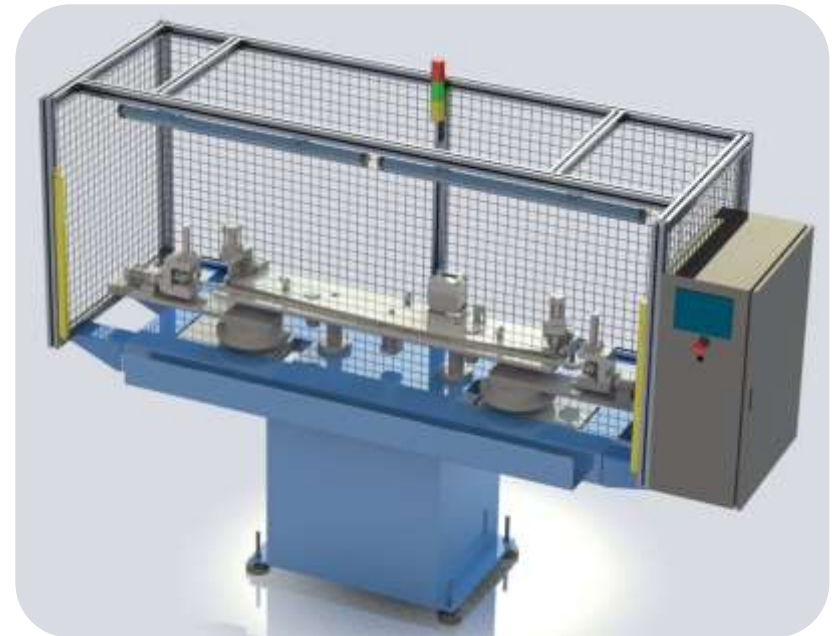

# Special-Purpose Machinery

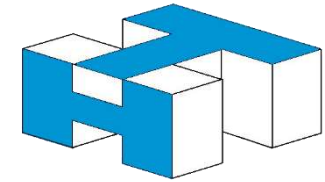

## Batch-off Cooling Machine

- Feeding conveyor
- Soaking bath
- Cooling festoon rack
- Stacking equipment
- Automated weighing and stacking

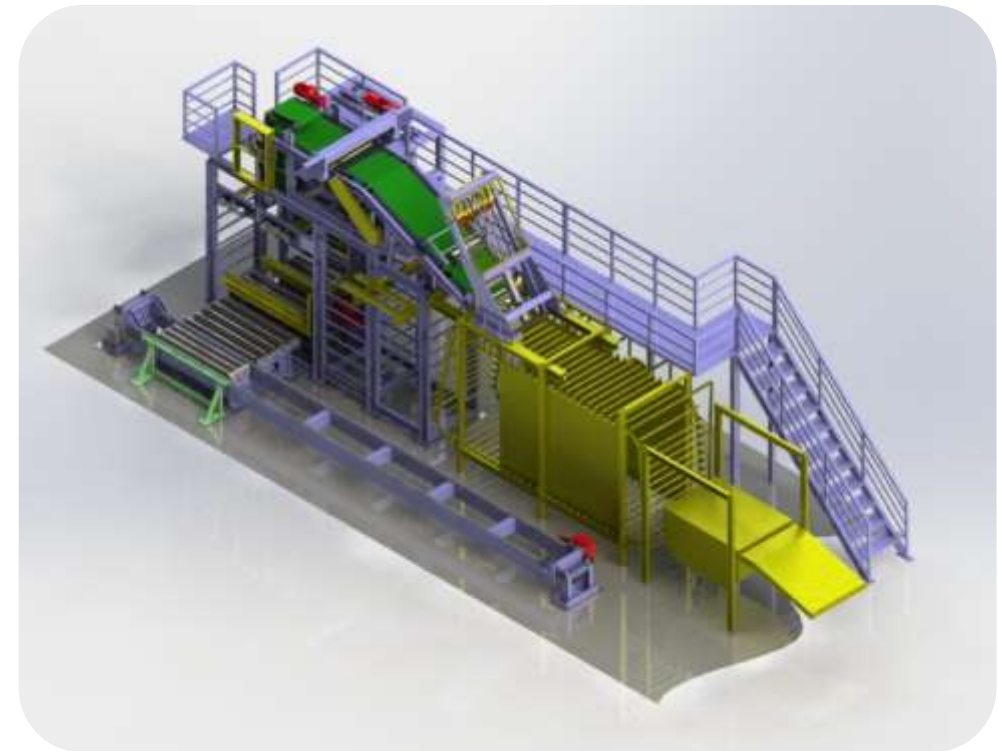

# Special-Purpose Machinery

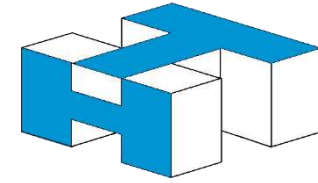

---

Production of pressurized hoses for air conditioning

# What We Do?

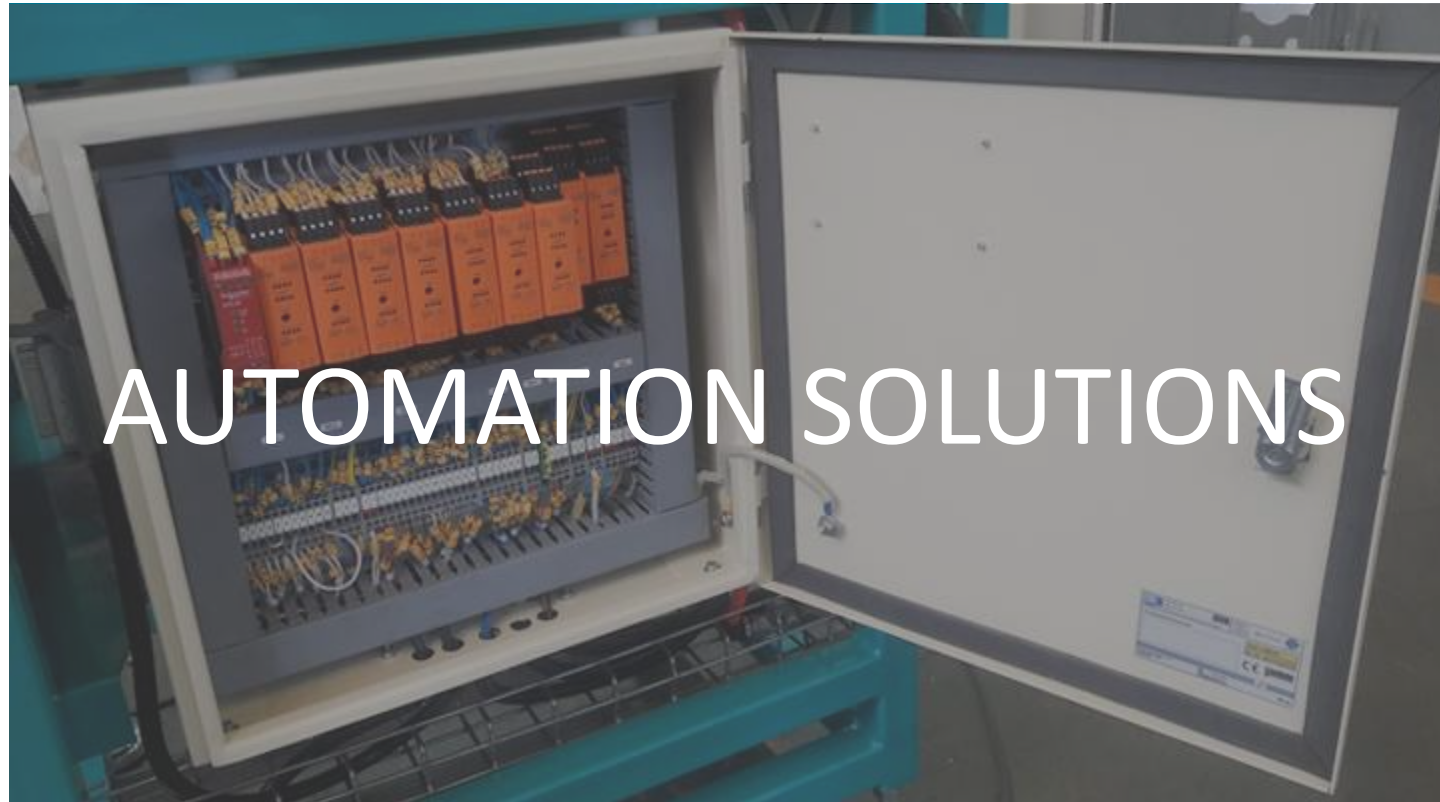
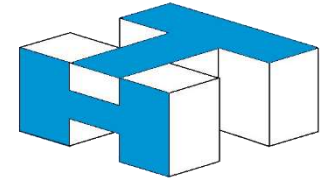

# Automation Solutions

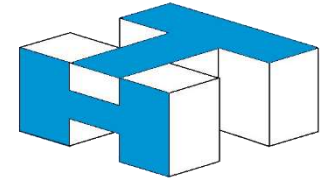

## Turnkey Automation Systems

- Motion control using servo motors and drives
- Industrial Control systems using PLCs, HMIs, sensors and actuators

## Assembly Automation Systems

- Robot integration for applications like material handling, palletizing, welding, coating, machine loading, assembly and etc.

## Industrial Inspection Automation Systems

- Vision systems for quality inspection, gauging and flaw detection



# Our Industrial Robots

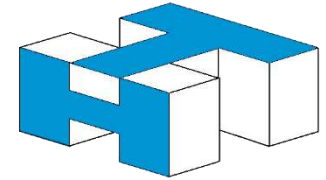

## Six DOF Industrial Grade Robot

Pay load: 20 kg  
Reach: 1400 mm  
Repeatability:  $\pm 0.05$  mm

## SCARA Robot

Pay load: 2 kg  
Reach: 650 mm  
Repeatability:  $\pm 0.02$  mm

## Delta Robot

Pay load: 2 kg  
Repeatability:  $\pm 0.1$  mm  
Vertical stroke: 300 mm  
Horizontal stroke: 700(300) mm

**The illustrated robots are designed and manufactured by Hamgar Toos.**

# Vision System

---

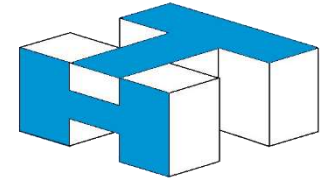

Machine vision systems employ a combination of software and hardware components to collect image-based information . This information is used to automate a variety of industrial applications including visual inspection, robot guidance, metrology, positioning and pattern recognition. Surface inspection and dimensional verification focus on qualitative parameters. In surface inspection any visual irregularities are inspected.

One of our successful vision projects was employing machine vision to inspect in-line quality of stamped metal carriers.

# Vision System

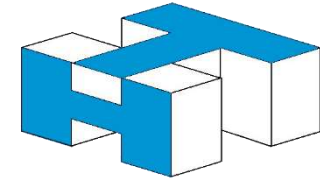

## Vision system for in-line quality inspection of stamped metal carriers

- Flaw detection in stamped metals
- Speed up accurate production
- Ceaseless inspection and measurement

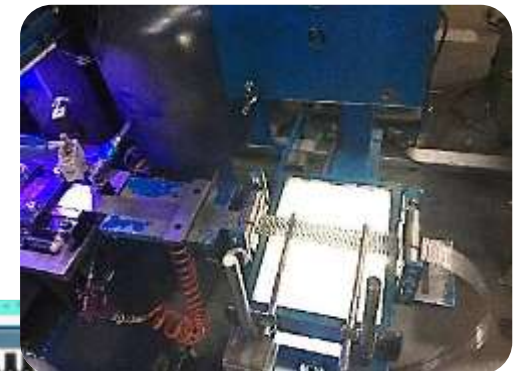

# Machinery Components

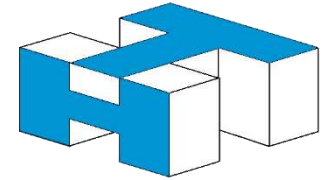

Component	Brand
Pneumatic	Pars Pneumatic
Hydraulic	Rexroth, HYSTAR
Automation	OMRON, SIEMENS
Drive & Motor	Panasonic, LS Mecapion

**Our machinery components can be customized according to the customer requirements.**

# What We Do?



Injection Molds  
&  
Tools

# Rubber Injection Molds

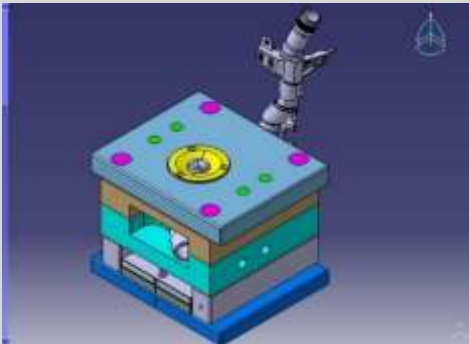

Plastic-to-Rubber Over  
Mold

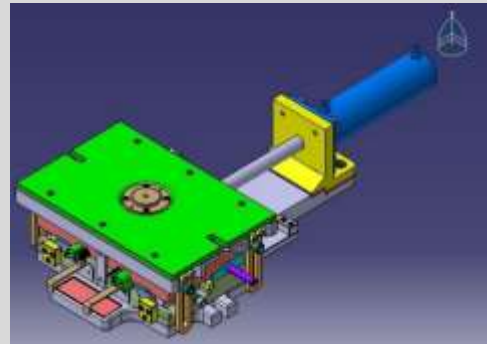

Corner Joint Rubber  
Mold



Sponge Rubber Mold



Metal Inserted Rubber  
Mold

# Rubber Injected Parts



Over-Molded Hose

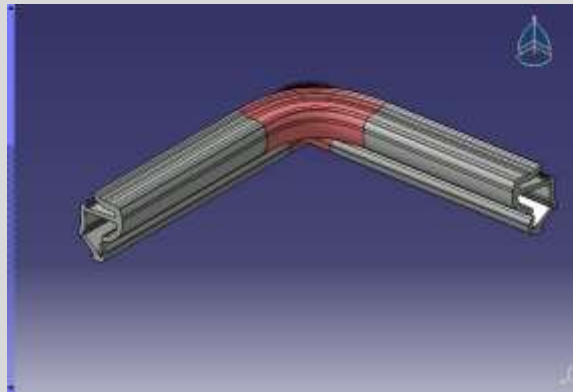

Corner joint

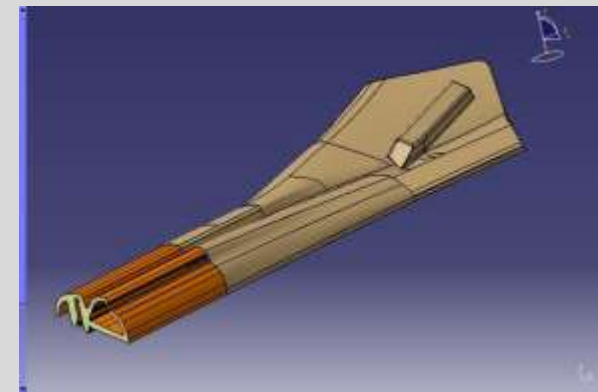

Rubber Profile

# Plastic Injection Molds



OWB Mold



Inflator Caps Mold



Belt Mold



# Checking Fixture



- Rubber & Plastic weather strips
- Rubber & Plastic Parts
- Metallic Parts



# Our Business Partner

---

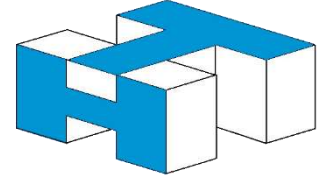

## **TURKUAZ RUBBER PLASTIC TEXTILE METAL AND FOREST PRODUCTS INDUSTRY AND TRADE COMPANY LIMITED**

Address: ALTINOVA MAH. NEW YALOVA YOLU CAD. BUTTİM İŞ MRK. NO: 424/5 / OFFICE NO: 2231 OSMANGAZİ BURSA, Turkey

Tel: +90 224 211 5400

Fax: +90 224 21101 52

Email: [burakusel@turkuazkaucuk.com](mailto:burakusel@turkuazkaucuk.com)

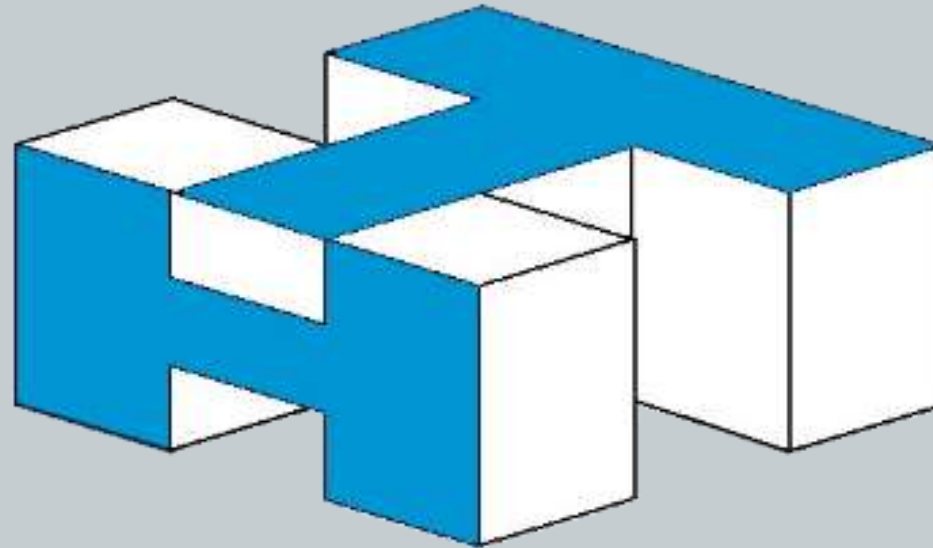

# Hamgar Toos Co.

Address: No 675, 5<sup>th</sup> Andisheh, 4<sup>th</sup> Danesh, Toos Industrial Estate, Mashhad, Iran

Tel: (+98)51 35413018

Fax: (+98)51 35413017

[www.hamgartoos.com](http://www.hamgartoos.com)

Email: [info@hamgartoos.com](mailto:info@hamgartoos.com)